



The Office of the National Coordinator for
Health Information Technology

PDMP FHIR® Implementation Guide and Pilots Overview

Project Briefing
February 20th, 2019



Agenda

- Introductions
- Overview of ONC
- Background on HL7[®] FHIR[®]
- Project Overview
- Project Phases
- Pilot Sites and Pilot Approach
- Pilot Example – LogiCoy Web App

Overview of ONC



- The Office of the National Coordinator for Health Information Technology (ONC) is the principal federal entity charged with coordination of nationwide efforts to implement and use the most advanced health information technology and the electronic exchange of health information.
- ONC is organizationally located within the Office of the Secretary for the U.S. Department of Health and Human Services (HHS).

ONC's Opioid-related Efforts

- ONC's current work focuses on utilizing health IT to help reduce the inappropriate use of opioids and opioid-related harms:
 - » Prescription Drug Monitoring Program (PDMP) & Health IT Data Integration – Data Standardization
 - » Clinical Decision Support (CDS)
 - » Electronic Prescribing of Controlled Substances (EPCS)
 - » ONC Health IT Certification Program to Support Care Continuum
 - » Policy Vehicles, Coordination, Stakeholder Engagement

HL7[®] FHIR[®] Basics

- The FHIR[®] (Fast Healthcare Interoperability Resources) is an HL7[®] standard for exchanging healthcare information electronically. FHIR leverages the latest web standards and keeps a focus on ease of implementation.
- HL7[®] FHIR[®] solutions are built from a set of modular components called "Resources". These resources are composed into working systems.
- FHIR[®] Supports 4 interoperability paradigms:
- Most implementations today focus on REST



HL7[®] FHIR[®] Basics (continued)

HL7[®] FHIR[®] features:

- » Open Source: community includes developers, vendors, health care providers
- » Extensible: resources can be extended in the framework
- » Composable: resources are combined into profiles
- » Documentation: included as part of the development process
- » Support for modern web standards: XML, JSON, HTTP, Atom, OAuth, REST.
- » Readable: every resource has a human-readable text representation
- » Secure: the SMART specification can be used in systems and stand-alone apps

HL7[®] FHIR[®] PDMP Standard

- The ONC PDMP FHIR project has developed and tested a standard that:
 - » Can enable low-cost access to PDMPs with minimal infrastructure requirements
 - » Is an open, non-proprietary HL7[®] standard
 - » Can be used in conjunction with existing standards (PMIX, NCPDP)
 - » Can support non-proprietary Clinical Decision Support (CDS) tools in development
 - » Is currently being piloted in several states

PDMP Standards Mapping and Balloting - Phases

- Phase 1 – PDMP FHIR Mapping
 - » 1/4/2018 - 6/4/2018
 - » IG balloted and approved at HL7®
- Phase 2 – PDMP FHIR Pilots
 - » 6/5/2018 - 6/4/2019
 - » Piloting with 3 states

PDMP FHIR – Project Phases

- **Phase 1 – PDMP FHIR Mapping**

- » Objective

- Develop a PDMP Implementation Guide (IG) to enable EHRs to access PDMPs using the HL7 FHIR standard and ballot the IG via HL7

- » Deliverables

- Mapping of HL7® FHIR® to NCPDP Script 10.6 and to PMIX 1.0 for request and response transactions
- PDMP IG (balloted and approved in June 2018)

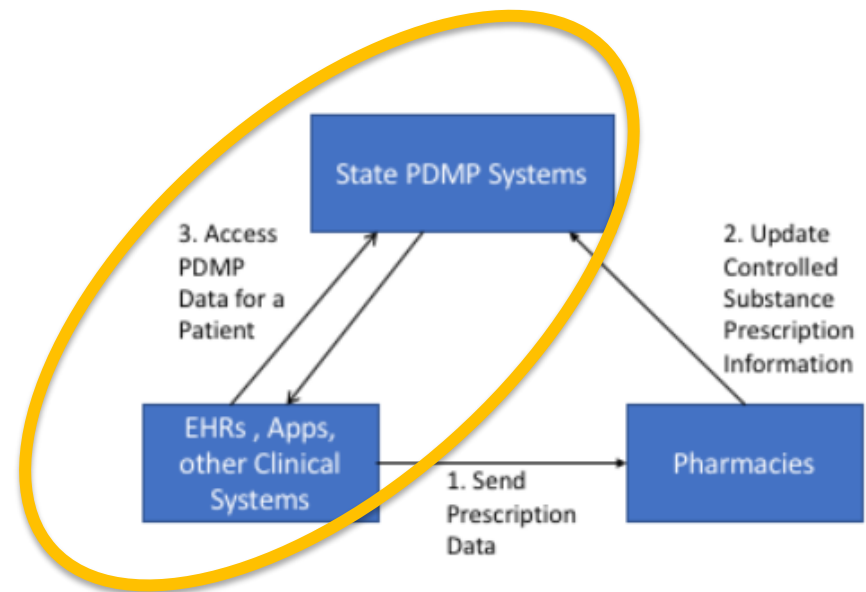

Transaction 3 (diagram) is only transaction in scope for the US Meds PDMP FHIR IG

HL7[®] FHIR[®] PDMP IG Details

PDMP IG Details

- Project used the US Core profiles and the US Meds profiles to request and receive PDMP data using FHIR[®] resources (no new FHIR[®] profiles were created)
- Request: 16 Data Elements mapped between PMIX and FHIR[®]
- Response: 46 Data Elements mapped between PMIX and FHIR[®]
- <http://hl7.org/fhir/us/meds/2018May/pdmp.html>
- The PDMP FHIR IG is built on FHIR[®] R3

PDMP FHIR – Project Phases

- **Phase 2 – PDMP FHIR Pilots**

- » Objective

- Provide support for the PDMP standards mapping and balloting efforts and refine the FHIR® standards through pilot testing

- » Goals:

- Implementation and testing of the PDMP FHIR® IG
- Refine mapping in the PDMP FHIR® IG (based on pilot findings)
- Revise and update the PDMP FHIR® IG based on project activities and pilot testing
- Update (and re-ballot if necessary) the updated PDMP FHIR IG at HL7®

- » Deliverables

- An updated PDMP FHIR® IG with pilot site input (and any other sources)

Pilot Scope

- Core Tasks
 - » Utilize HL7[®] FHIR[®] PDMP IG to implement both routes in test environments
 - Direct route testing: FHIR[®] server to be hosted at IL PDMP for IL
 - Intermediary route testing: FHIR[®] server to be hosted by LogiCoy for KY & UT
 - » Capture lessons learned to update and refine the PDMP FHIR[®] IG
- Potential Tasks
 - » Integration of PDMP data into EHR systems via FHIR[®] (in sandbox)
 - » Gathering clinician feedback on use

Pilot Sites

- Illinois (Department of Human Services)
 - » Path: Direct to PMP
- Kentucky (Department of Health)
 - » Path: Intermediary (RxCheck) along with LogiCoy converter
- Utah (Department of Health)
 - » Path: Intermediary (RxCheck) along with LogiCoy converter

Pilot Approach

- Direct Route (IL)
 - » FHIR® server at PDMP data store
 - Outside FHIR® clients (e.g., a SMART App) connect to FHIR® server
 - FHIR® server directly connects to data store
 - FHIR® server returns results to FHIR clients

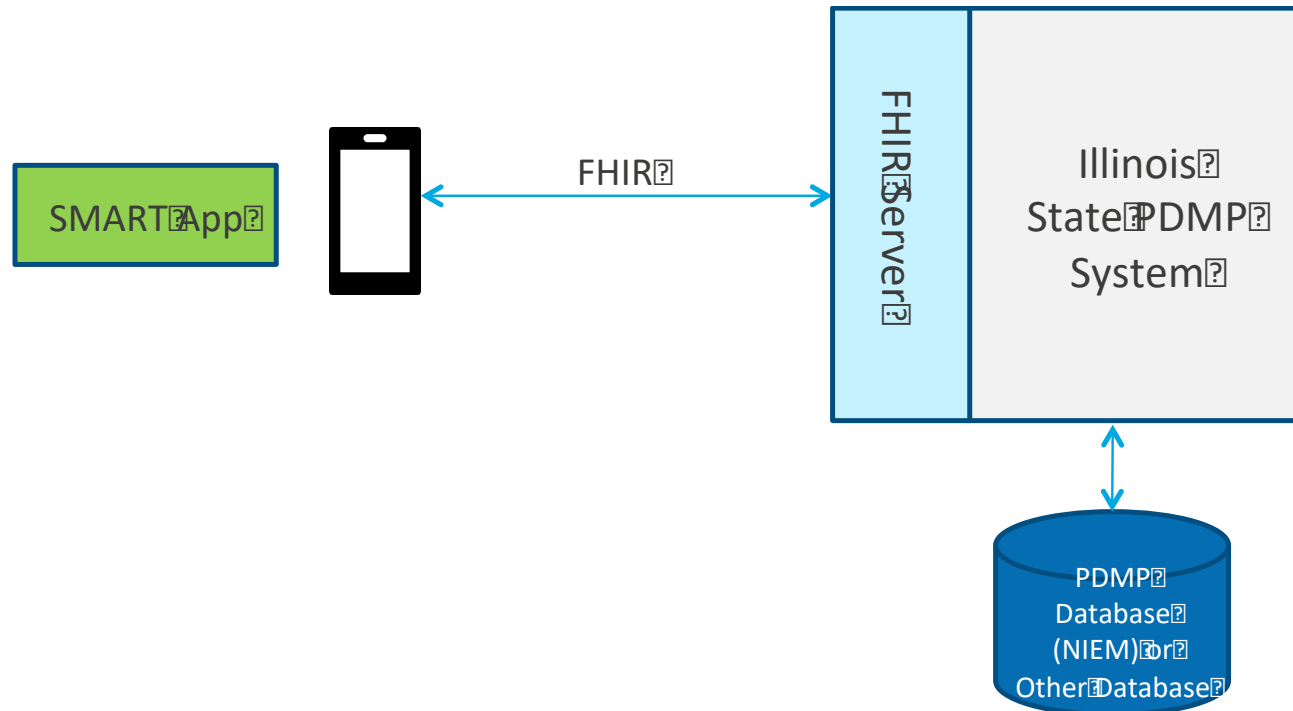

Pilot Approach

- Intermediary Route (KY, UT)

- » FHIR® converter upstream from intermediary

- Outside FHIR® clients connect to LogiCoy FHIR converter
- FHIR® converter translates from FHIR, queries data store via intermediary, obtains results, translates back to FHIR
- FHIR® converter returns results to FHIR clients

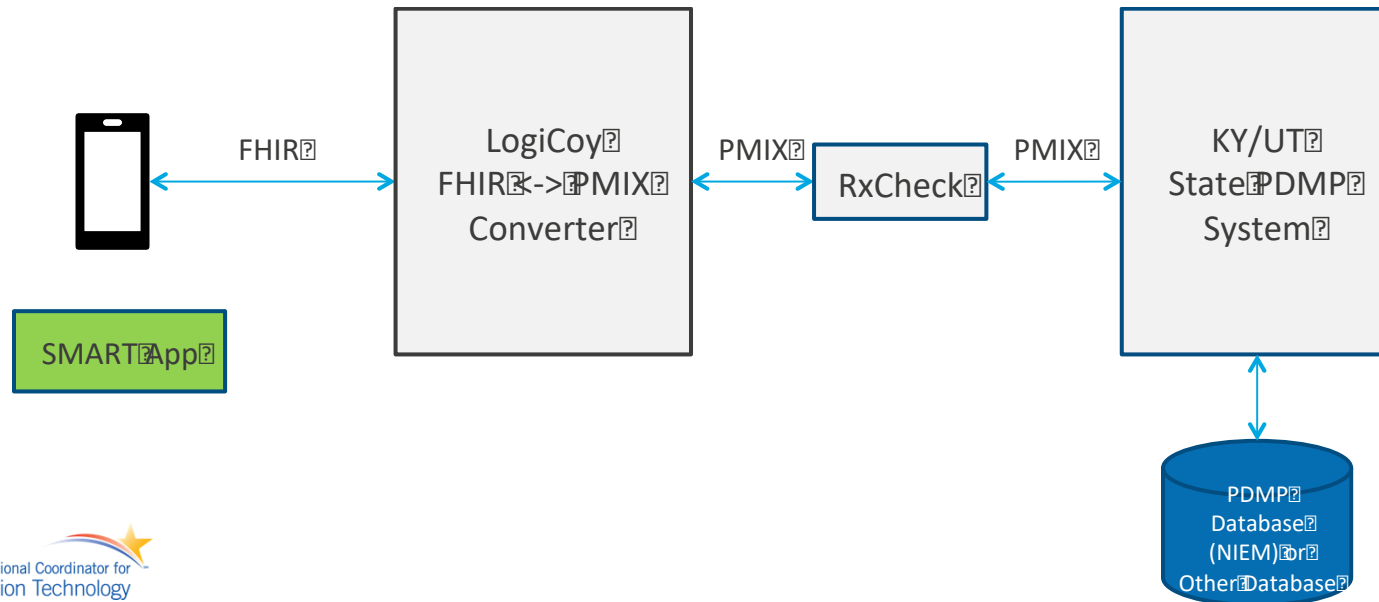

Pilot Example and SMART on FHIR Demo

- Illinois Pilot - Utilizing the LogiCoy SMART on FHIR® web app
 - » Using test data from the Illinois PDMP
 - » This app can also connect to other states via RxCheck
 - » There are iOS and Android versions of the web app
 - » ***Note: This SMART on FHIR® app was developed independently by LogiCoy and is not an ONC product nor sponsored by ONC.***

IL LogiCoy Web App: Prescriptions View

LogiCoy

Patient Prescription Analysis

PDF Report | Text Report

Sherlock Holmes
 Age: 65 years 0 months
 D.O.B: 01-06-1954
 Address: 6890 HARTWIG DR, 40W553 R...
 Date: 01-08-2019

50 Prescriptions
 16 Prescribers
 15 Pharmacies

MME Details
 Average MME/day: 31.75
 Current MME/day: 0.00

Risk Analysis

Prescriptions | Prescribers | Pharmacies

Show 10 entries

Id	Filled	Written	Drug	Qty	Days	Strength	RX#	MME/Day	Prescriber	Pharmacy	Patid
580078	2018-12-26	2018-12-25	TESTOSTERONE CYPIONATE	3	30	200MG/ML	00574082001	0.0	NA	WALGREENS #12555	1
577704	2018-12-15	2018-12-15	CARISOPRODOL	60	30	250 MG	42543043401	0.0	NA	WALGREENS #12555	1
572109	2018-11-22	2018-11-22	HYDROCODONE BIT/ACETAMIN	90	30	325-10 MG	00591261205	30	NA	WALGREENS #12555	1
572115	2018-11-22	2018-10-28	TESTOSTERONE CYPIONATE	3	30	200 MG/ML	62756001540	0.0	NA	WALGREENS #12555	1

IL LogiCoy Web App: Pharmacies View

LogiCoy

Patient Prescription Analysis

PDF Report | Text Report

Sherlock Holmes
 01-06-1954
 6890 HARTWIG DR CHERRY VALLEY IL 61016
 PatId: 1

SHERLOCK HOLMES
 01-06-1954
 40W553 ROUTE 64 GENEVA IL 60183
 PatId: 2

Sherlock Holmes
 01-06-1954
 6890 HARTWIG DR VERIFY DOB CHERRY VALLEY IL 61016
 PatId: 3

SHERLOCK HOLMES
 01-06-1954
 524 N LA LONDE AVE LOMBARD IL 60148

Summary:
 50 Prescriptions
 16 Prescribers
 15 Pharmacies

MME Details:
 Average MME/day: 31.75
 Current MME/day: 0.00

Risk Analysis:

Prescriptions | Prescribers | **Pharmacies**

Show 10 entries | Search:

Name	Address	City	State	Zip	DEA
WALGREENS #12555	2404 S PERRYVILLE RD	ROCKFORD	IL	61108	FW1400845
WALGREENS	2525 S ALPINE RD	ROCKFORD	IL	61104	BB6039843
WALGREEN CO.	3351 W MAIN STREET	ST CHARLES	IL	60175	BW7612268
WALGREENS	727 S MAIN	LOMBARD	IL	60148	AW2345254
CVS CAREMARK	1780 WALL ST	MT PROSPECT	IL	60056	FC3186815
WALGREENS	1601 N WELLS	CHICAGO	IL	60614	AW7672505
HY-VEE PHARMACY #1519	4125 N. SHERIDAN RD., #20	PEORIA	IL	61614	FH2068371

IL LogiCoy Web App: Prescribers View

The screenshot shows the LogiCoy Patient Prescription Analysis web application. The browser address bar indicates the URL: <https://openid.logicoy.com/pdmpwebappfeccommon/layout/home>. The page title is "Patient Prescription Analysis".

Navigation and Controls:

- Left sidebar: "LogiCoy" logo, "Select all" (checked), "De-select all", "Update" button.
- Top right: "PDF Report" and "Text Report" buttons.

Patient Summary:

- Sherlock Holmes**, Age: 65 years 0 months, D.O.B: 01-06-1954, Address: 6890 HARTWIG DR, 40W553 R..., Date: 01-08-2019.

Summary Metrics:

- 50 Prescriptions
- 16 Prescribers
- 15 Pharmacies

MME Details:

- Average MME/day: 31.75
- Current MME/day: 0.00

Risk Analysis: A gauge chart showing a low risk level.

Filtering and Search:

- Active filter: "Prescribers" (under Prescriptions, Prescribers, Pharmacies tabs).
- Show 10 entries
- Search:

Table of Prescribers:

Name	Address	City	State	Zip	DEA
NA NA	NA				AE2303888
NA NA	NA				AM2455473
NA NA	NA				MG3989095
NA NA	NA				BH3973218
NA NA	NA				AD2826696
NA NA	NA				BP0754792
NA NA	NA				BS2923680

Questions and Discussion

Contact Information

- **ONC**
 - » Mera Choi, mera.choi@hhs.gov
 - » JaWanna Henry, Jawanna.Henry@hhs.gov
 - » Lolita Kachay, Lolita.Kachay@hhs.gov
- **PDMP FHIR Project Team**
 - » Mike Flanigan, mike.flanigan@carradora.com
 - » Brett Marquard, brett@waveoneassociates.com
 - » Nagesh (Dragon) Bashyam, nagesh.bashyam@drajer.com
 - » Amy Benson, amy.benson@carradora.com
- **LogiCoy**
 - » Fred Aabedi, fred.aabedi@logicoy.com